



DOBOT

User Guide

Sliding Rail User Guide

Issue: V1

Date: 2018-09-11

Shenzhen Yuejiang Technology Co., Ltd

Copyright © ShenZhen Yuejiang Technology Co., Ltd 2018. All rights reserved.

No part of this document may be reproduced or transmitted in any form or by any means without prior written consent of Yuejiang Technology Co., Ltd

Disclaimer

To the maximum extent permitted by applicable law, the products described (including its hardware, software and firmware, etc.) in this document are provided **AS IS**, which may have flaws, errors or faults. Yuejiang makes no warranties of any kind, express or implied, including but not limited to, merchantability, satisfaction of quality, fitness for a particular purpose and non-infringement of third party rights. In no event will Yuejiang be liable for any special, incidental, consequential or indirect damages resulting from the use of our products and documents.

Before using our product, please thoroughly read and understand the contents of this document and related technical documents that are published online, to ensure that the robotic arm is used on the premise of fully understanding the robotic arm and related knowledge. Please use this document with technical guidance from professionals. Even if follow this document or any other related instructions, Damages or losses will be happen in the using process, Dobot shall not be considered as a guarantee regarding to all security information contained in this document.

The user has the responsibility to make sure following the relevant practical laws and regulations of the country, in order that there is no significant danger in the use of the robotic arm.

Shenzhen Yuejiang Technology Co., Ltd

Address: 3F, Building NO.3, Tongfuyu Industrial Town, Nanshan District, Shenzhen, China

Website: www.dobot.cc

Preface

Purpose

This document is a tutorial for the Sliding Rail kit of Dobot Magician. It will teach you how to install the Sliding Rail kit and write with the brush.

Intended Audience

This document is intended for:





- Customer Engineer
- Sales Engineer
- Installation and Commissioning Engineer
- Technical Support Engineer

Change History

Date	Change Description
2018/09/11	Updated the connection figure between Dobot Magician and sliding rail
2018/08/23	The first release

Symbol Conventions

The symbols that may be founded in this document are defined as follows.

Symbol	Description
 DANGER	Indicates a hazard with a high level of risk which, if not avoided, could result in death or serious injury
 WARNING	Indicates a hazard with a medium level or low level of risk which, if not avoided, could result in minor or moderate injury, robotic arm damage
 NOTICE	Indicates a potentially hazardous situation which, if not avoided, can result in robotic arm damage, data loss, or unanticipated result
 NOTE	Provides additional information to emphasize or supplement important points in the main text

Contents

1. Operating Sliding Rail.....	1
1.1 Installing sliding rail	1
1.2 Sliding Rail Parameter Description.....	6
1.3 Demo Description	7

1. Operating Sliding Rail

When the workspace of Dobot Magician is not enough, you can extend it with the sliding kit, such as long-distance picking and placing, a large range of writing and so on. Figure 1.1 shows the sliding rail kit and Table 1.1 lists its description.

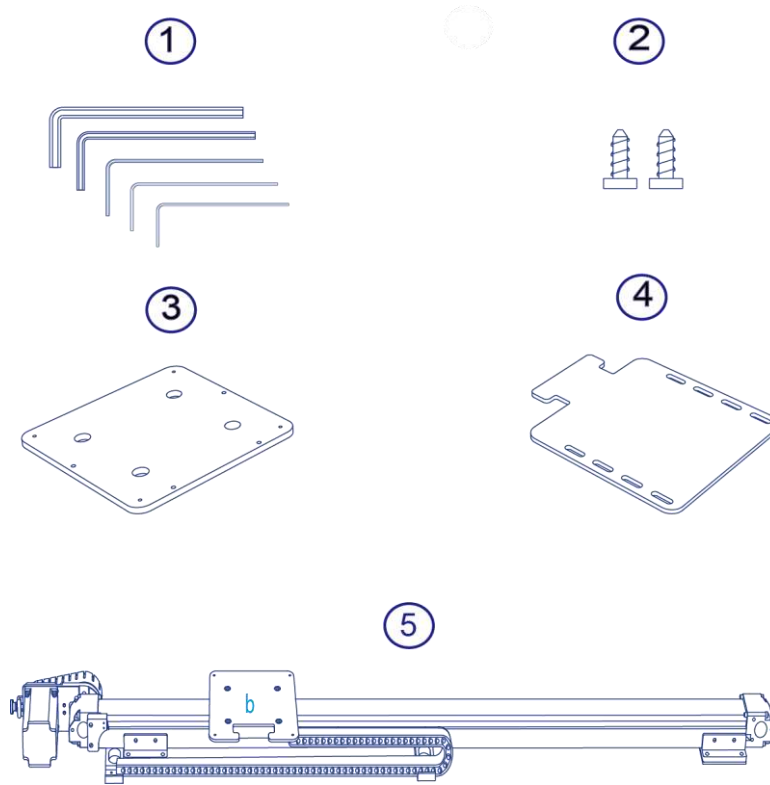

Figure 1.1 Sliding rail kit

Table 1.1 Sliding rail kit description

No.	Description
1	Tool kit
2	Screws
3	Plate a
4	Plate c
5	Sliding rail (with wire set and plate b)

1.1 Installing sliding rail

Procedure

Step 1 Mount Dobot Magician on the plate **a** with four M3*10 countersunk head cap screws

Make The counter bore of plate an outward), as shown in Figure 1.2.

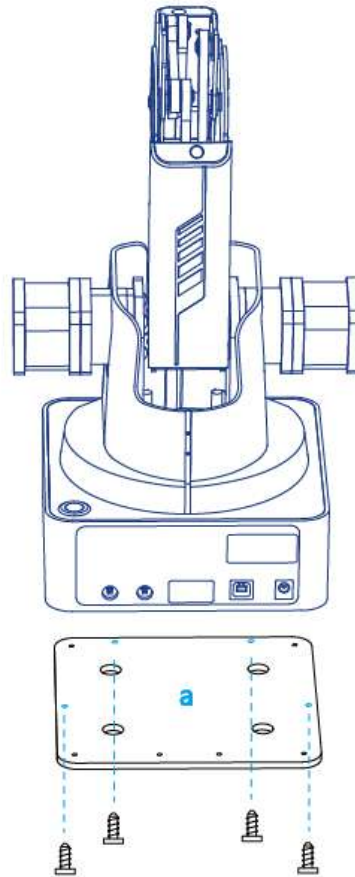

Figure 1.2 Fix plate a

Step 2 Fix the plate **a** (with Dobot Magician) on the plate **b** with three M3*8 hexagon socket head cap screws. Please make the back of the base of Dobot Magician towards the rabbet on the plate **b**, as shown in Figure 1.3.

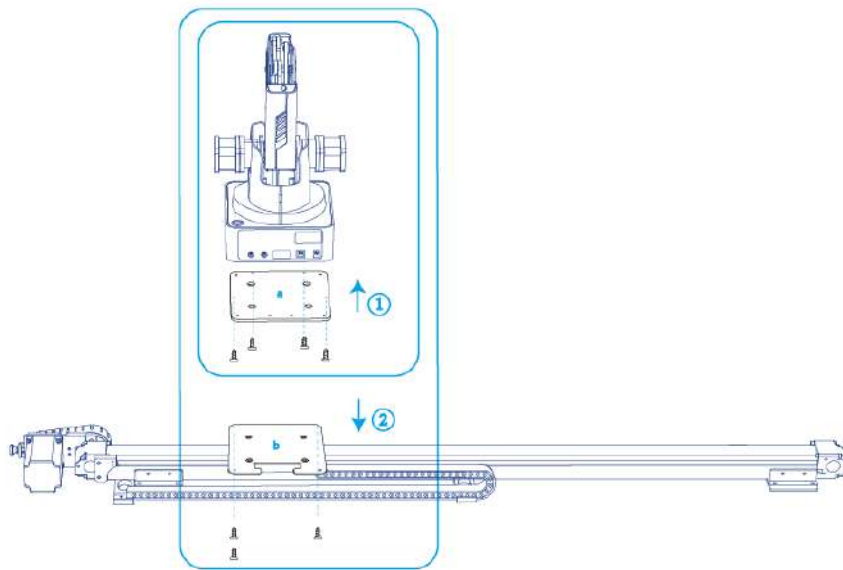

Figure 1.3 Fixed position with screws

Step 3 Connect the end of the wire set to the plate b with a M3*6 countersunk head hexagon screw, as shown in Figure 1.4.

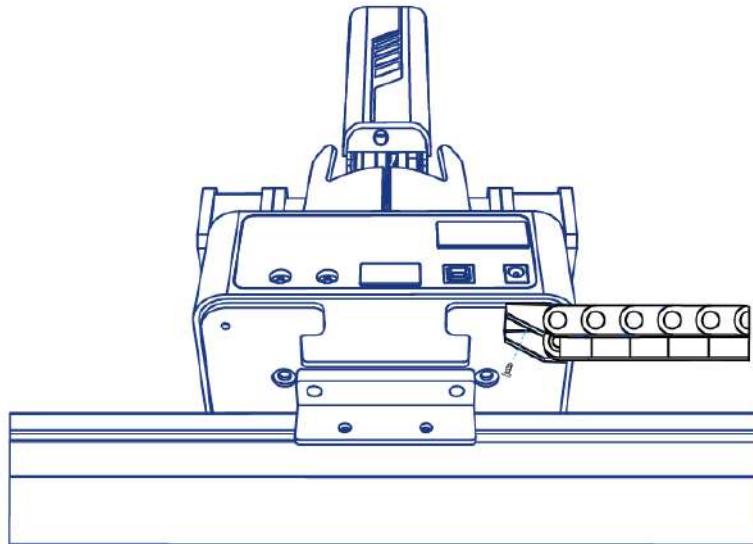

Figure 1.4 Connect with wire set

Step 4 (Optional) Fix plate c. This step is required only when using air pump for picking and placing or other tasks.

1. Fix the plate **c** on the plate **a** with two M3*8 hexagon socket head cap screws, as shown in Figure 1.5.

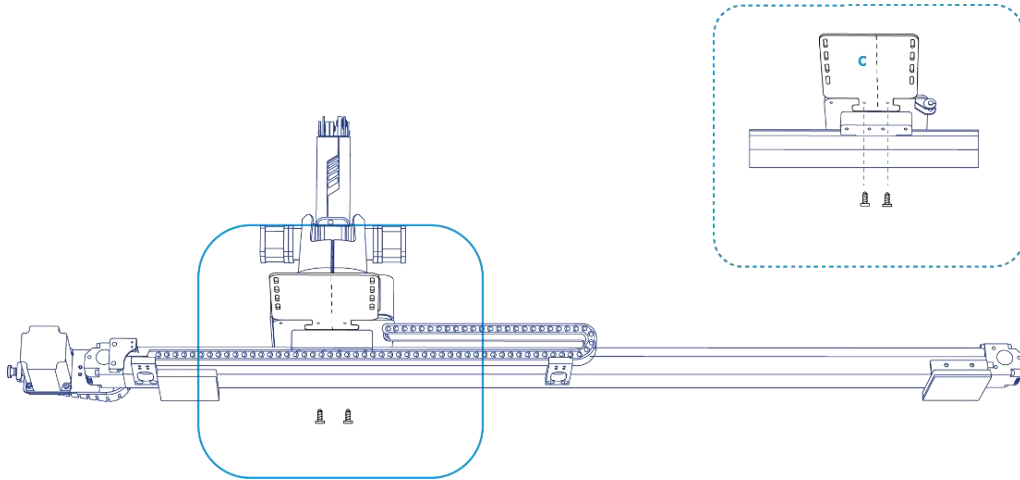

Figure 1.5 Fix plate **c**

2. Fix the air pump on the plate **c**, as shown in Figure 1.6. And connect the air pump to Dobot Magician, as shown in Figure 1.7.

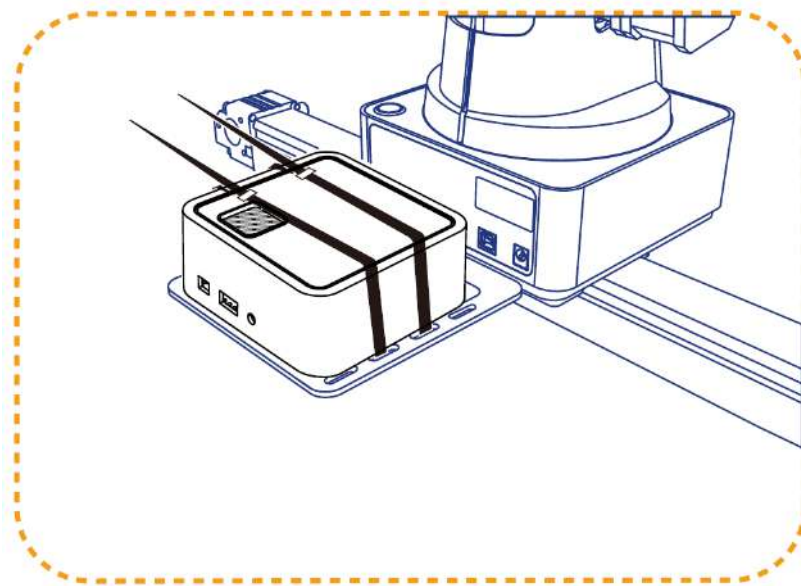

Figure 1.6 Fix air pump



Figure 1.7 connect the air pump to Dobot Magician

Step 5 Connect the interfaces on the end of the wire set to Dobot Magician, as shown in Figure 1.8.

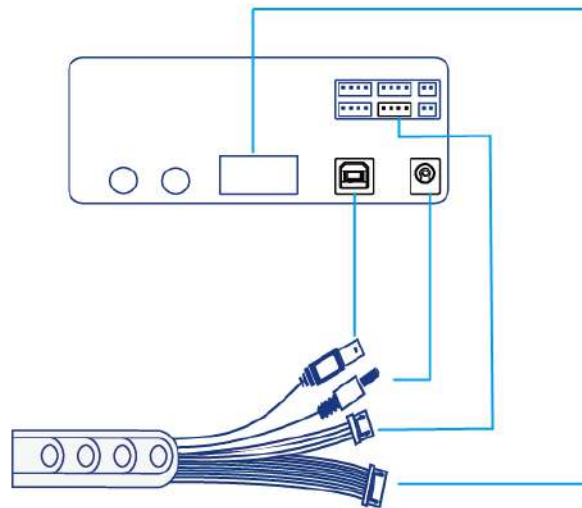

Figure 1.8 Connect to Dobot Magician

Step 6 Connect the interfaces on the other end of the wire set to the power adaptor, USB interface of PC, motor interface and homing interface of the sliding rail respectively. Figure 1.9 shows the interfaces on the other end of the wire set.

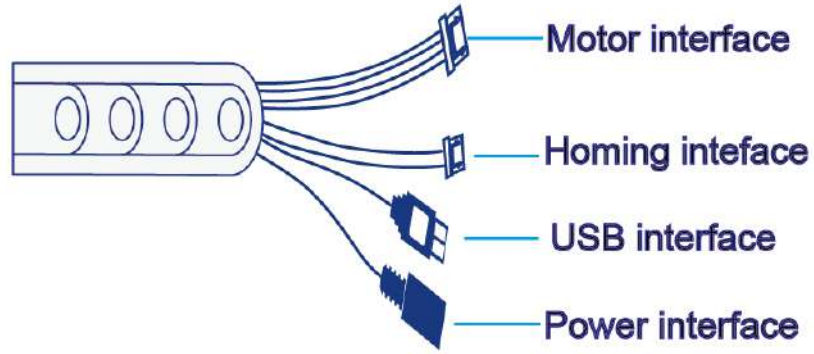

Figure 1.9 Interfaces on the other end of the wire set

Figure 1.10 shows the connection between the sliding rail and the wire set.

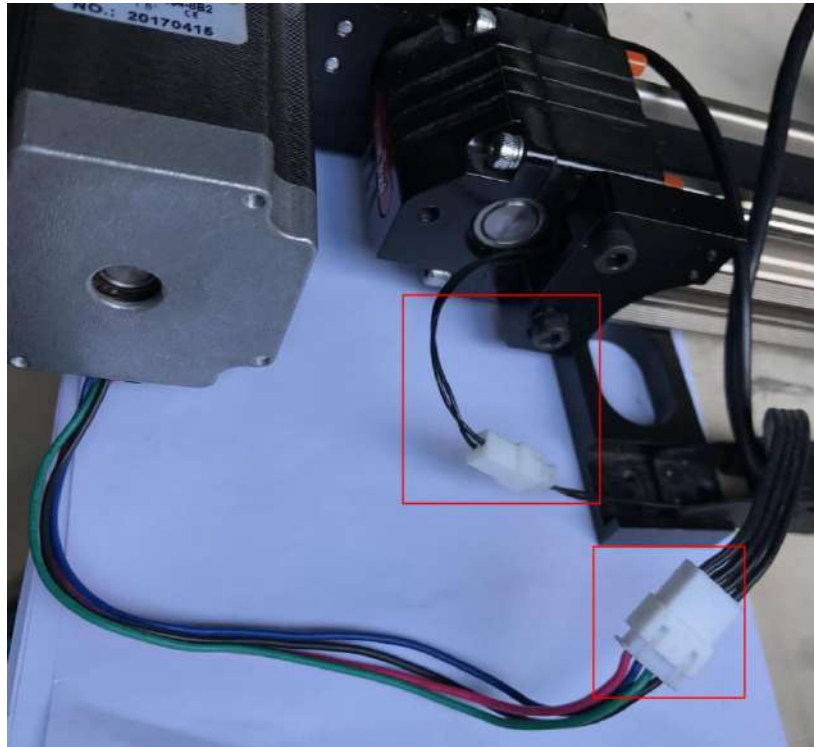

Figure 1.10 Connect sliding rail and wire set

1.2 Sliding Rail Parameter Description

Table 1.2 Sliding rail parameter description

Parameter	Description
Maximum payload	5kg
Maximum Distance	1000mm
Maximum speed	150mm/s
Maximum acceleration	150mm/s ²
Repeated positioning accuracy	0.01mm
Absolute positioning accuracy	0.25mm

1.3 Demo Description

This topic describes how to use sliding rail for writing.

Prerequisites

- The sliding rail has been installed and connected to the Dobot Magician.
- Dobot Magician has been powered on. Dobot Magician has been connected to DobotStudio successfully.
- The writing kit has been installed.
- The PLT files have been prepared.

Procedure

Step 1 Open DobotStudio, click **LinearRail** and choose **Linear Rail control** on the DobotStudio page.As shown in Figure 1.11.



Figure 1.11 Click LinearRail

Step 2 Click **L+** or **L-** to test whether sliding rail can move properly. As shown in Figure 1.12

- Available distance sliding rail of: 0mm~1000 mm.
- Maximum load: 5kg.

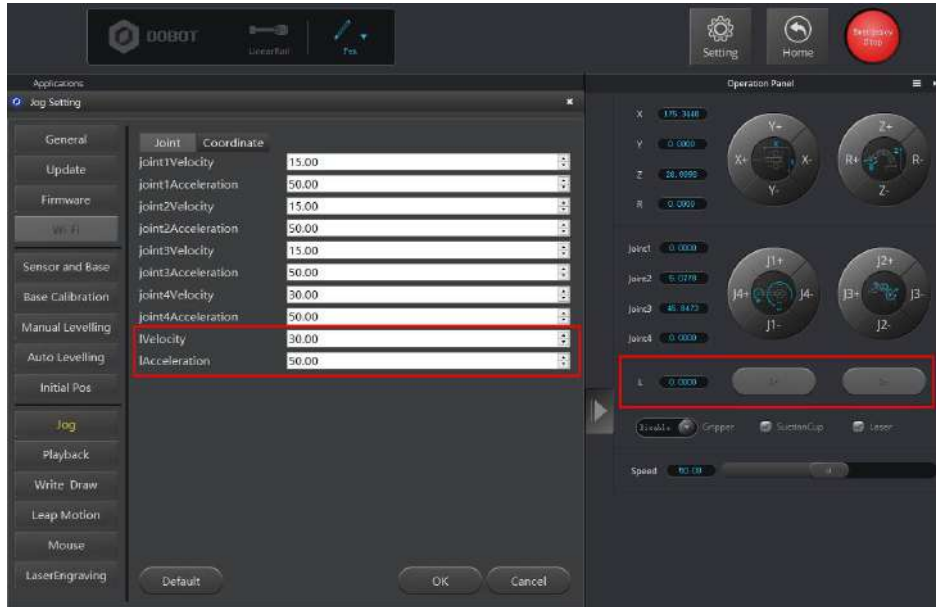

Figure 1.12 LinearRail motion test

Step 3 Click **Home** on the DobotStudio page. As shown in Figure 1.13.

The sliding block moves to its homing point, and then Dobot Magician rotates back to its homing point.

NOTICE

Before you Click **Home**, please take the pen off or raise the Dobot Magician arm up.



Figure 1.13 Home test

Step 4 Click **Write&Draw** to enter the **Write&Draw** page. As shown in Figure 1.14.

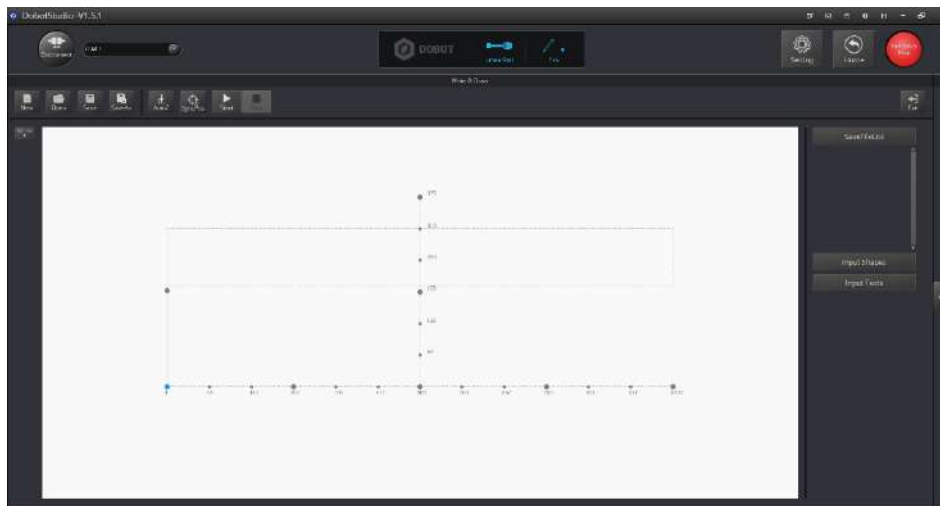

Figure 1.14 LinearRail operation panel

Step 5 Click **open** to import the PLT files. As shown in Figure 1.15.

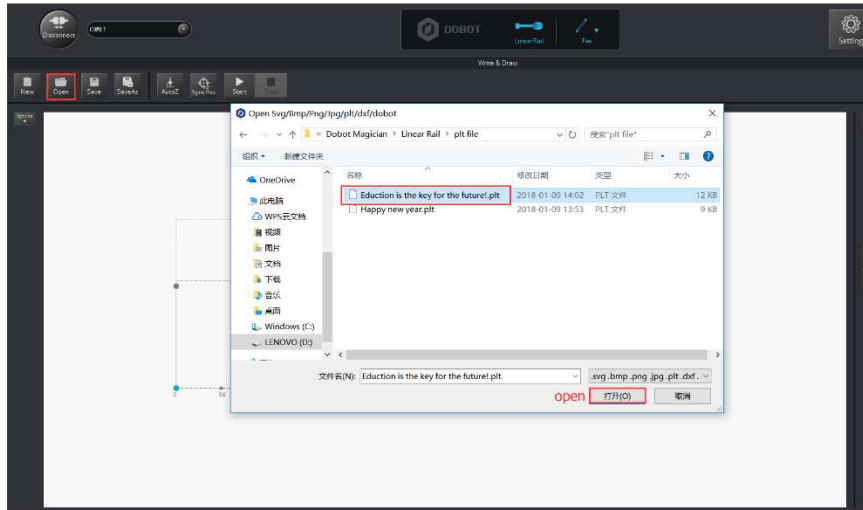

Figure 1.15 Import file

Step 6 Click options on the left side of the **Write&Draw** page to adjust position and size of characters. As shown in Figure 1.16.

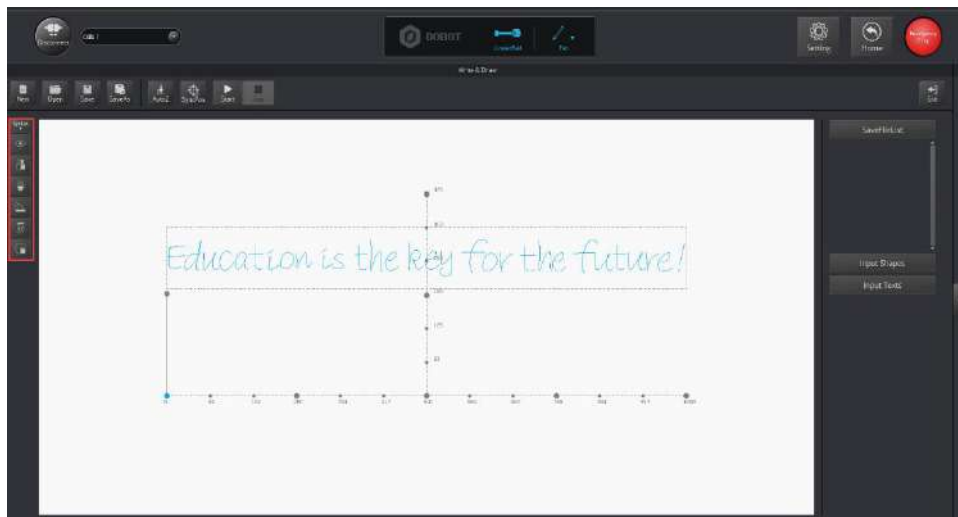

Figure 1.16 Operation Panel

Step 7 Adjust the height of pen. If you want to write bold characters, you should make the pen more close to the paper. According to your needs to adjust it appropriately. As shown in Figure 1.17.

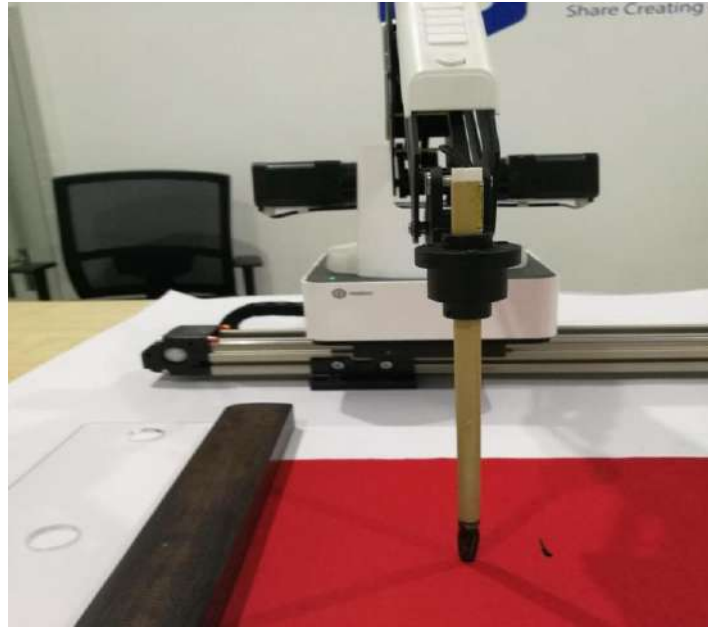

Figure 1.17 Adjust the height of pen

Step 8 Click **AutoZ** to save the height of pen and the position coordinate of Z-axis. As shown in Figure 1.18.

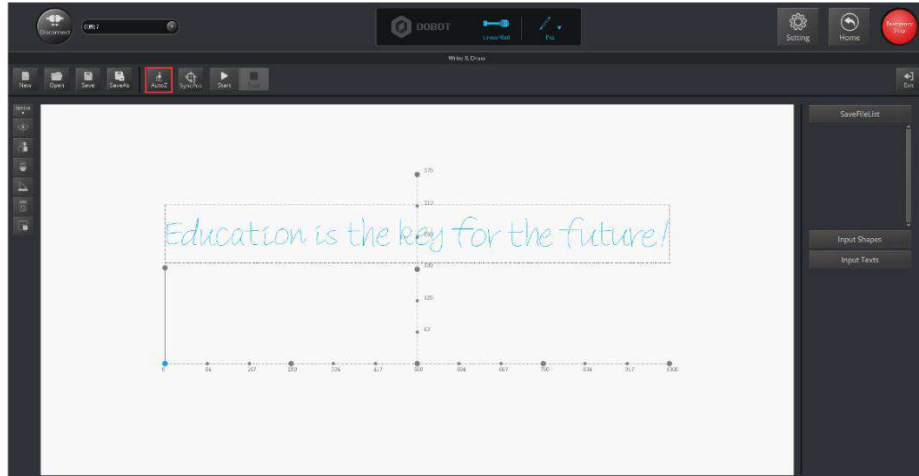

Figure 1.18 save the position coordinate of Z-axis and pen height

Step 9 (Optional) Set playback trigger and ink dipping position.

NOTICE

If you want to set an action to dip the pen into the ink, you can press Unlock Key and drag the Dobot Magician to a point, and then release to get this point position on the **Teaching & Playback** page. For the details please refer to the steps below.

1. Right-click the blank space on the **Write&Draw** page and select **Add a playback trigger**. As shown in Figure 1.19

NOTE

A playback trigger causes an ink dipping motion.

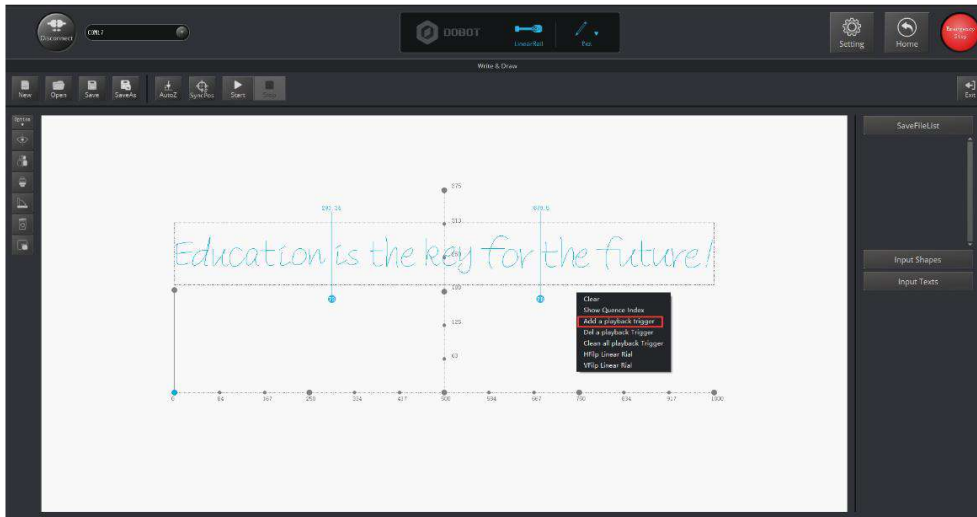

Figure 1.19 Set dip ink position

2. Click **Teaching & Playback** to enter the **Teaching & Playback** page for setting ink dipping actions. As shown in Figure 1.20.

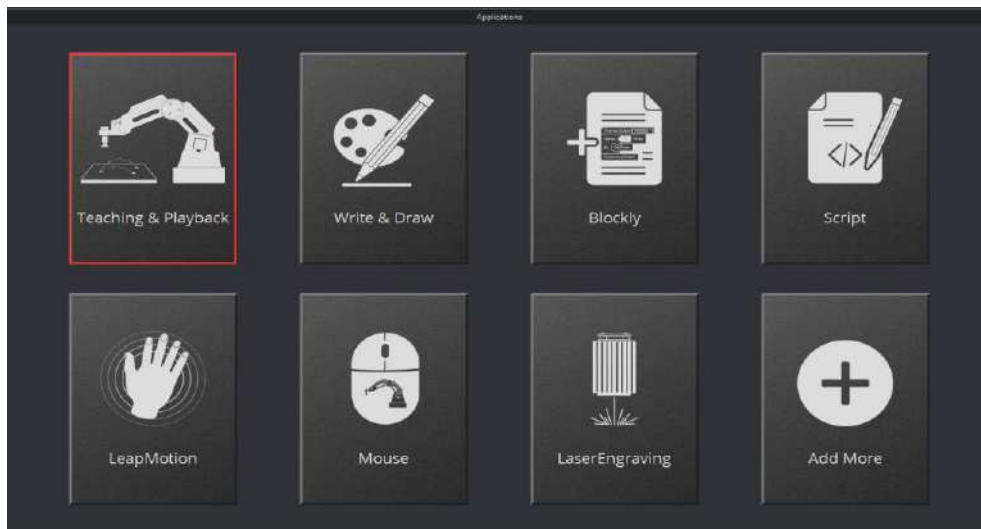

Figure 1.20 Return to Teaching&Playback

3. Press the Unlock Key on the Forearm, move the Forearm over the upper portion of the writing area, and release the Unlock Key to record the first point position. As shown in Figure 1.21.

 NOTICE

Make this point higher within the Dobot Magician workplace to prevent the writing brush from touching the inkstone.



Figure 1.21 Recording the first point position

4. Move the Forearm to the following inkstone positions shown in Figure 1.22 and Figure 1.23, and record these points on the **Teaching & Playback** page.



Figure 1.22 Simulate the actions of ink dipping 1



Figure 1.23 Simulate the actions of ink dipping 2

5. Drag the Forearm to raise the writing brush up, to avoid touching the inkstone. As shown in Figure 1.24.

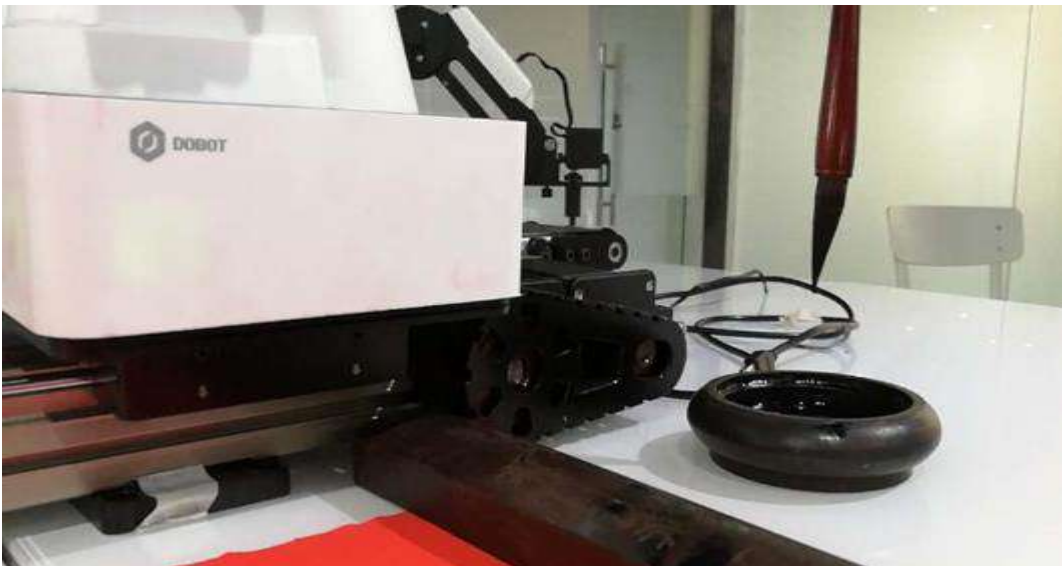

Figure 1.24 Raise the writing brush

⚠ NOTICE

The inkstone has its own height, so you need to set a suitable rising height to prevent the writing brush from touching the inkstone. Click **Setting > write Draw > PenUpOffset** to set the height that we recommend is 50mm to 70mm.

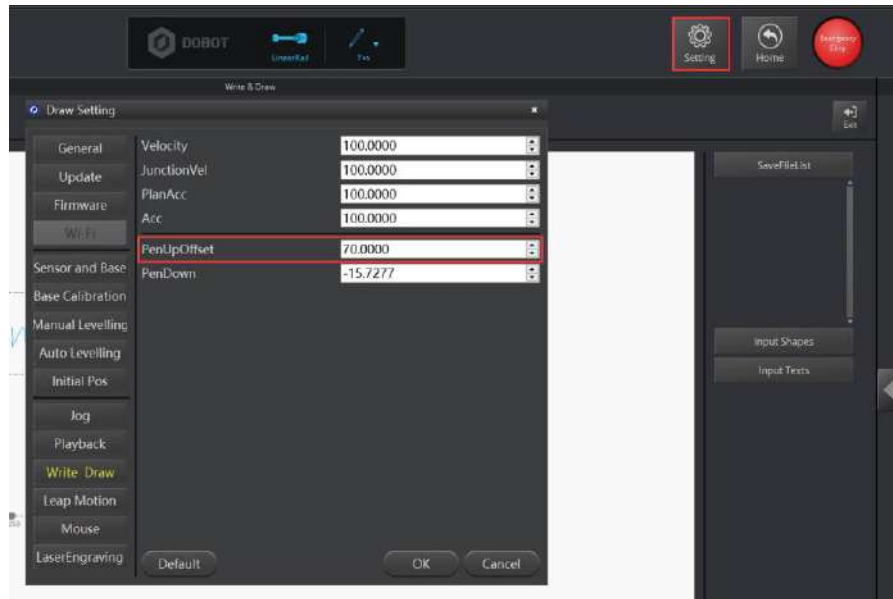

Figure 1.25 Set a suitable rising height

Step 10 Click **SyncPosition** on the **Write&Draw** page, and then the Dobot will move to the initial position. As shown in Figure 1.26.

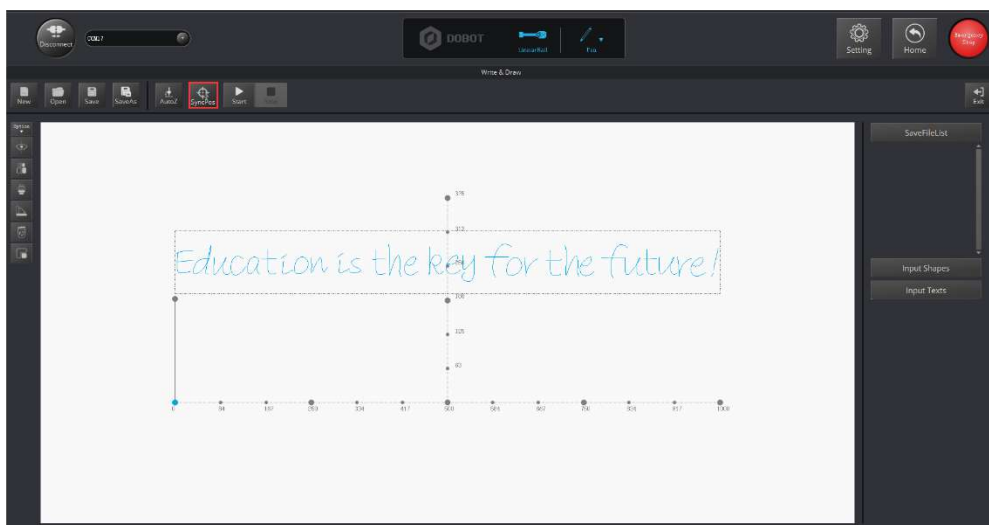

Figure 1.26 SyncPosition

Step 11 Click **Start**, the Dobot will write automatically.