



DOBOT

User Guide

Dobot Vision Kit Installation Guide

Issue: V1.0

Date: 2019-09-12

ShenZhen Yuejiang Technology Co., Ltd.

Copyright © ShenZhen Yuejiang Technology Co., Ltd. 2019. All rights reserved.

No part of this document may be reproduced or transmitted in any form or by any means without prior written consent of Yuejiang Technology Co., Ltd.

Disclaimer

To the maximum extent permitted by applicable law, the products described (including its hardware, software and firmware, etc.) in this document are provided **AS IS**, which may have flaws, errors or faults. Yuejiang makes no warranties of any kind, express or implied, including but not limited to, merchantability, satisfaction of quality, fitness for a particular purpose and non-infringement of third party rights. In no event will Yuejiang be liable for any special, incidental, consequential or indirect damages resulting from the use of our products and documents.

Before using our product, please thoroughly read and understand the contents of this document and related technical documents that are published online, to ensure that the robotic arm is used on the premise of fully understanding the robotic arm and related knowledge. Please use this document with technical guidance from professionals. Even if follow this document or any other related instructions, Damages or losses will be happen in the using process, Dobot shall not be considered as a guarantee regarding to all security information contained in this document.

The user has the responsibility to make sure following the relevant practical laws and regulations of the country, in order that there is no significant danger in the use of the robotic arm.

ShenZhen Yuejiang Technology Co., Ltd.

Address: Floor 9-10, Building 2, Chongwen Garden, Nanshan iPark, Liuxian Blvd, Nanshan District, Shenzhen, Guangdong Province, China

Website: <https://www.dobot.cc/>

Preface

Purpose

This document describes the Dobot vision kit and its installation, making it easy for users to fully understand and use it.

Intended Audience

This document is intended for:





- Customer Engineer
- Sales Engineer
- Installation and Commissioning Engineer
- Technical Support Engineer

Change History

Date	Change Description
2019/09/09	Update vision kit specification and installation
2018/04/27	The first release

Symbol Conventions

The symbols that may be founded in this document are defined as follows.

Symbol	Description
 DANGER	Indicates a hazard with a high level of risk which, if not avoided, could result in death or serious injury
 WARNING	Indicates a hazard with a medium level or low level of risk which, if not avoided, could result in minor or moderate injury, robotic arm damage
 NOTICE	Indicates a potentially hazardous situation which, if not avoided, can result in robotic arm damage, data loss, or unanticipated result
 NOTE	Provides additional information to emphasize or supplement important points in the main text

Contents

1. Vision Kit Description	1
1.1 Overview.....	1
1.2 Vision Kit List.....	1
1.3 Camera Parameters Description.....	1
1.4 Light Source Parameters Description	2
1.5 Camera Lens Parameters Description	3
2. Installation Guide.....	4
2.1 Installing Camera.....	4
2.2 Installing Dobot Magician	14
2.3 Installing Dobot M1	14

1. Vision Kit Description

1.1 Overview

The image processing system extracts the characteristics of the objects via setting the range of Hue, Saturation, Value and pixel area of the images obtained from vision kit, transforms image coordinates into Cartesian coordinates and transmits to robot. Therefore, we can use robot to complete intelligent sorting and other operations.

1.2 Vision Kit List

Figure 1.1 shows the vision kit list.

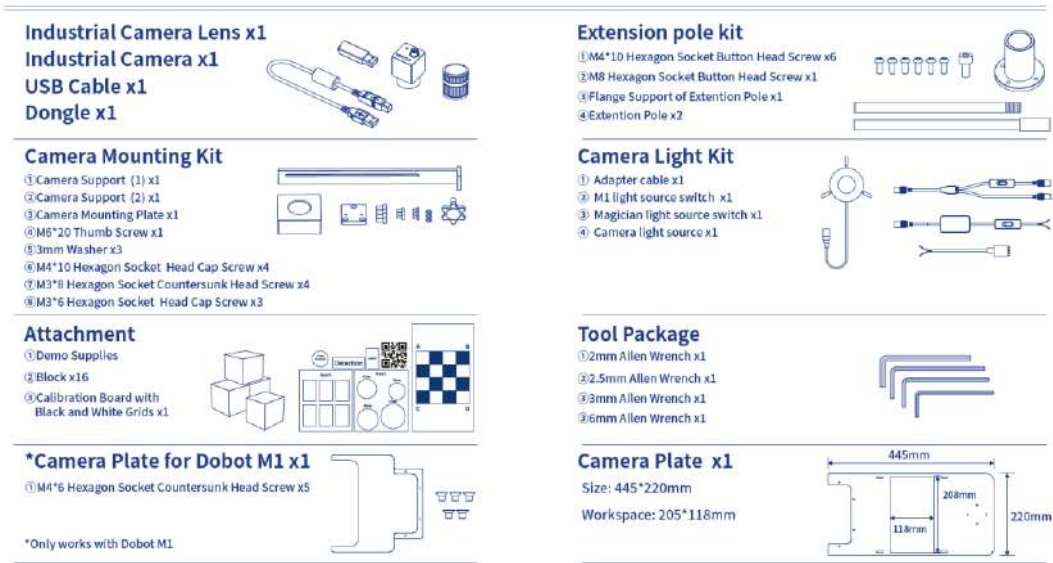

Figure 1.1 Vision kit list

1.3 Camera Parameters Description

Table 1.1 Camera Parameters Description

Parameters	Description
Camera model	MV-CE050-30UC
Sensor size	1/2.5"CMOS
Sensor model	AR0521
Effective pixels	5,000,000 pixels
Color	Color
Pixel Size	2.2umx2.2um
Frame rate/Resolution	31 @2592×1944
SNR	>40dB

Parameters	Description
Dynamic range	>60dB
Shutter type	Rolling shutter
Exposure time	<ul style="list-style-type: none"> Bayer format: 16μs-1sec Other formats: 28μs-1sec
Exposure control	Automatic/Manual
Dimension	29mm*29mm*30mm
Data interface	USB3.0
Operating temperature	0~50° C
Lens mount	Mount C

1.4 Light Source Parameters Description

Table 1.2 Light Source Parameters Description

Parameters	Description
Light source model	JHZM-A40-W
Emitting color	White
LED quantity	48 light-emitting diode
Illumination	40000Lux
Brightness	Continuously adjustment, adjustable range: 0% -100% The color temperature remains unchanged
Wavelength	455nm-457.5nm
Output voltage	12V
Output power	3.5W~5W
Working distance	35mm-110mm
Specifications	<ul style="list-style-type: none"> Internal diameter: 40mm External diameter: 70mm Height: 25mm
Ring Diameter Inside	Max ϕ 39mm
Weight	0.48KG
Working environment	<ul style="list-style-type: none"> Temperature: 0°C-40°C Humidity: 20%RH-85RH

Parameters	Description
Storage environment	<ul style="list-style-type: none"> • Temperature: -20°C-40°C • Humidity: 20%RH-85RH

1.5 Camera Lens Parameters Description

Table 1.3 Camera Lens Parameters Description

Parameters		Description	
Lens model		MVL-HF1228M-6MP	
Focal distance		12mm	
Maximum imaging size		1/1.8 " (ϕ 9mm)	
Aperture range		F2.8-F16	
Control mode	Aperture	Manual	
	Focus	Manual	
Field angle	D	1/1.8 "	41.2°
	H		34.4°
	V		23.4°
Operating temperature		-10°C+50°C	
Optical distortion		-0.38%	
Back focal length		17.526mm	
Shortest photography distance		0.06m	
Mount		Mount C	
Filter		M27*0.5	
Size		ϕ 29mm*35.36mm	

2. Installation Guide

2.1 Installing Camera

Procedure

Step 1 Fix the camera flange support to the bottom of the extension pole with screws.



Figure 2.1 Install camera flange support

Step 2 Connect the two extension poles.



Figure 2.2 Connect the two extension poles

Step 3 Fix the end of the extension pole with Camera flange support to the camera holder using four M4*10 Hexagon Socket Button Head Screw.

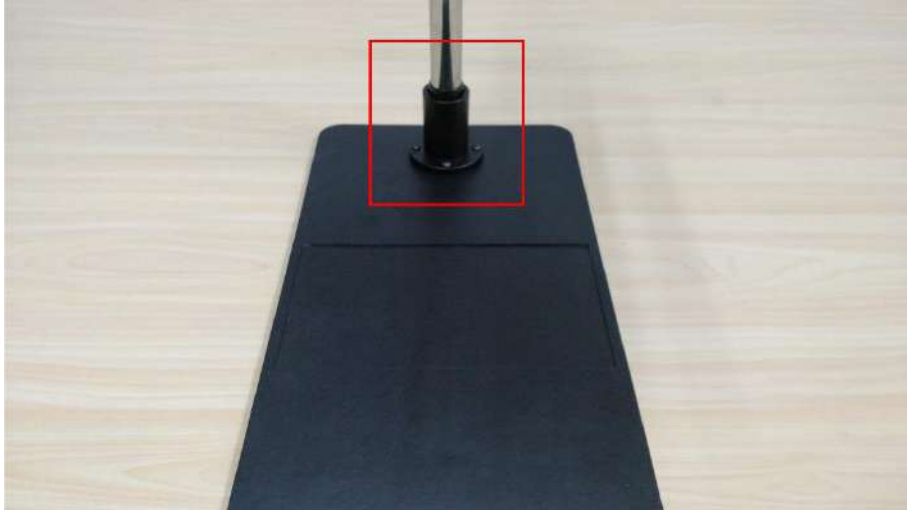

Figure 2.3 Fix extension pole

Step 4 (Optional) If robot is Dobot M1, you have to assemble the two camera plates with M4*6 hexagon socket countersunk head screws.

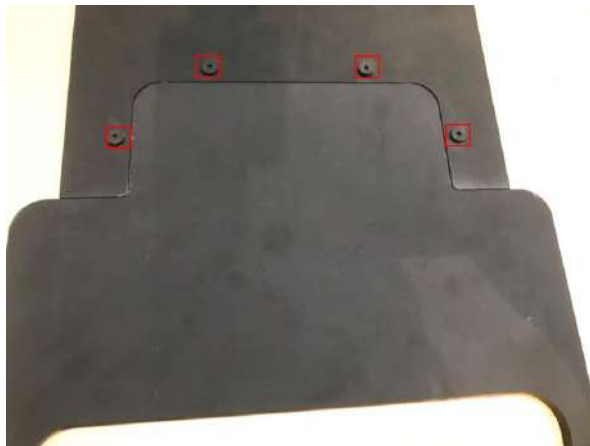

Figure 2.4 Assemble two plates

Step 5 Assemble camera support (1) and camera support (2) with two M4*10 hexagon socket head cap screws. Figure 2.5 shows the installation style.



Figure 2.5 Install camera support

Step 6 Fix the camera support to the extension pole by adjusting the stationary fixture.



Figure 2.6 Fix the camera support

! NOTICE

Please adjust the height of the camera support based on site requirements. The camera support cannot hinder the movement of robot.

Step 7 Fix the camera to the camera mounting plate with three M3*8 hexagon socket countersunk head screws.



Figure 2.7 Fix camera plate

Step 8 Fix the camera mounting plate to the camera support (2) with two M3*6 hexagon socket head cap screws and two washers.



Figure 2.8 Fix camera mounting plate

Step 9 Connect camera to computer with USB cable (plug blue connector into USB3.0 interface of computer).



Figure 2.9 Connect camera to computer

Step 10 Adjust camera parameters.

MVS is a software which can adjust camera parameter. You can get the installation package from installation package of DobotVisionStudio.

Preparations:

- MVS has been installed.
- Camera has been connected to computer.

Procedures:

1. Run MVS, and click  to connect camera.

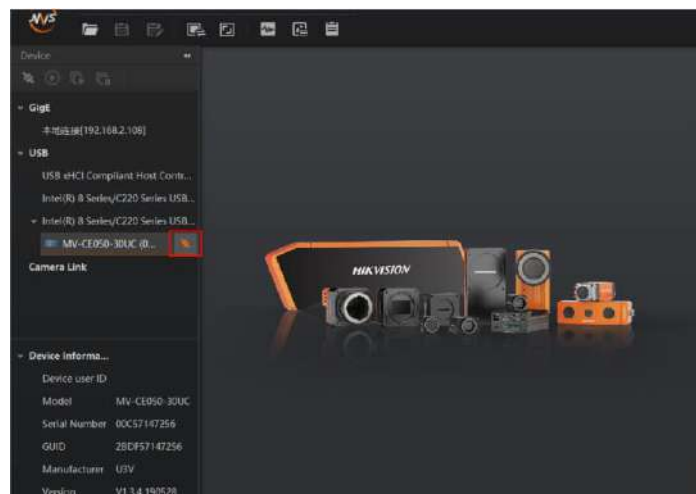

Figure 2.10 Connect camera

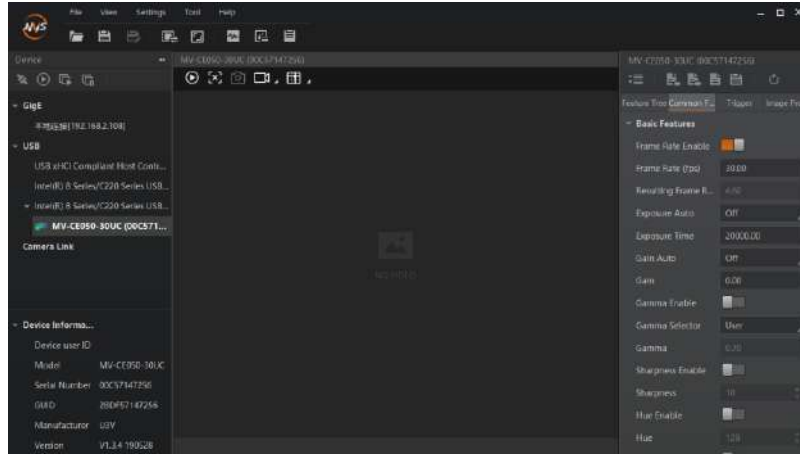

Figure 2.11 Connect camera successfully

2. Click  to capture imaging.

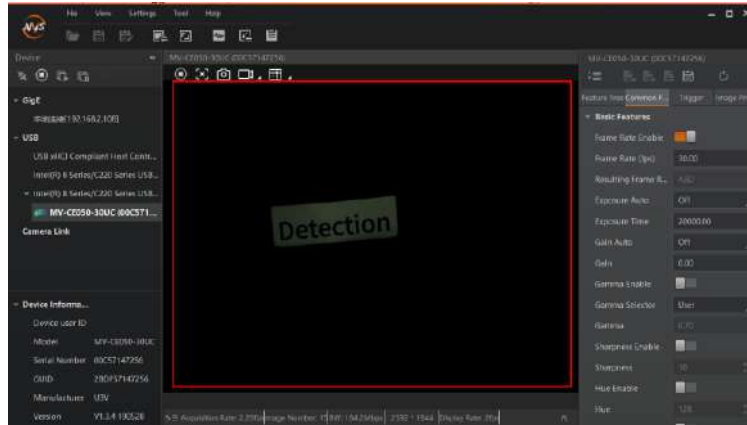

Figure 2.12 Capture imaging

3. Adjust focal length, aperture, and exposure time according to image.
 - Adjust image by rotating around the focal length, and lock focal length by rotating helix switch.



Figure 2.13 Adjust focal length

⚠ NOTICE

If there is not enough light in the environment, turn on the light source. Please turn on or off the light source depending on the actual requirements. For the installation of light source, please refer to Step 11 and Step 12.

- Adjust brightness by rotating aperture, and lock aperture by rotating helix switch.



Figure 2.14 Adjust aperture

- Adjust exposure time or other parameters based on site requirements until imaging can be appeared clearly.

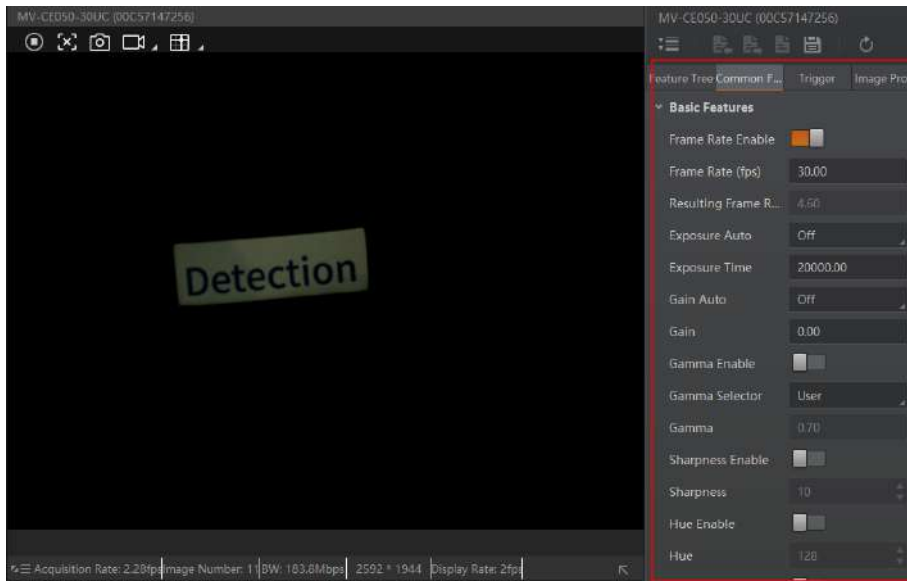

Figure 2.15 Adjust exposure time or other parameters

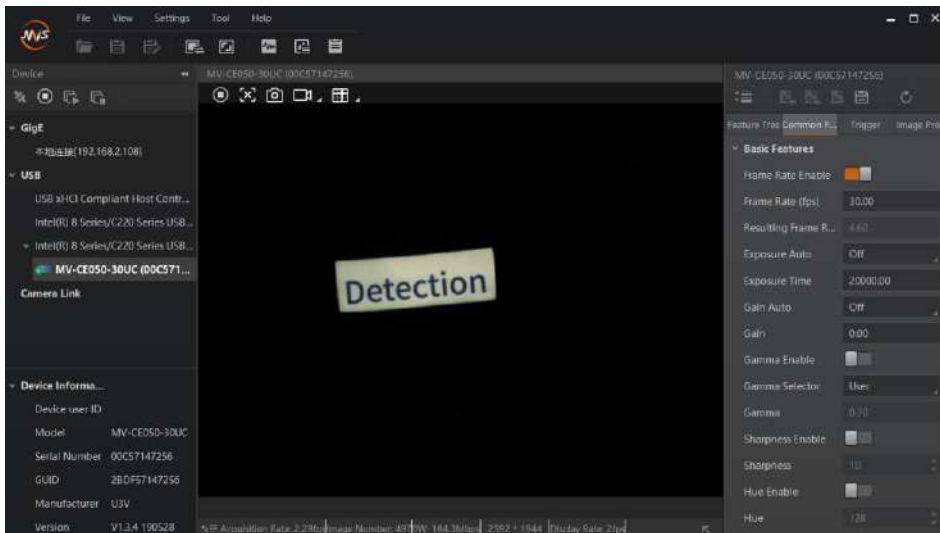

Figure 2.16 Result imaging

Step 11 Attach the light source kit to the camera, and fasten the kit with its three fixing knobs.



Figure 2.17 Fasten the light source kit

Step 12 Connect light source switch.

- **Connect light source switch to Magician**
 1. Connect light source switch to light source.
 2. Connect light source switch to the power interface of Dobot Magician.
 3. Connect light source switch to the power adapter of Dobot Magician.



Figure 2.18 Connect light source switch

- **Connect light source switch to M1**
 1. Connect adapter cable to M1 light source switch, the red interfaces are 24V power interfaces, the black interfaces are GND interfaces.
 2. Connect M1 light source switch to light source.
 3. Connect adapter cable to I/O interface on the base of Dobot M1.



Figure 2.19 Connect light source switch

NOTICE

If you need to use light source switch and air pump box at the same time. Please connect the power cable of air pump box to adapter cable. As shown below, the red interfaces are 24V power interface, the black interfaces are GND interface.

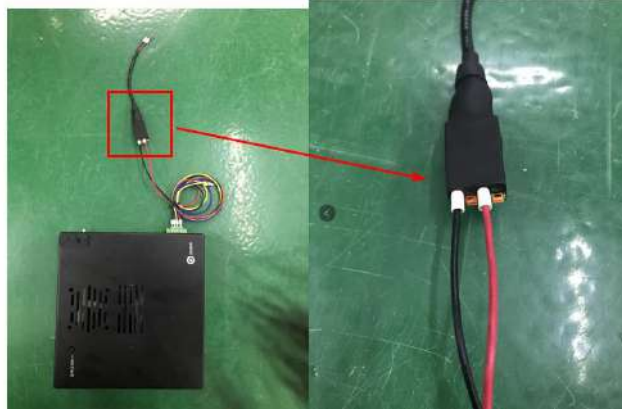

Figure 2.20 Connect air pump box

2.2 Installing Dobot Magician

Procedure

- Step 1** Fix Dobot Magician to the platform. For details, please see *Dobot Magician User Guide*.
- Step 2** Adjust the camera support to ensure that the camera can view the workspace of Dobot Magician.



Figure 2.21 Install Dobot Magician

2.3 Installing Dobot M1

- Step 1** Fix Dobot M1 to the platform. For details, please see *Dobot M1 User Guide*.
- Step 2** Adjust the camera support to ensure that the camera can view the workspace of Dobot M1.

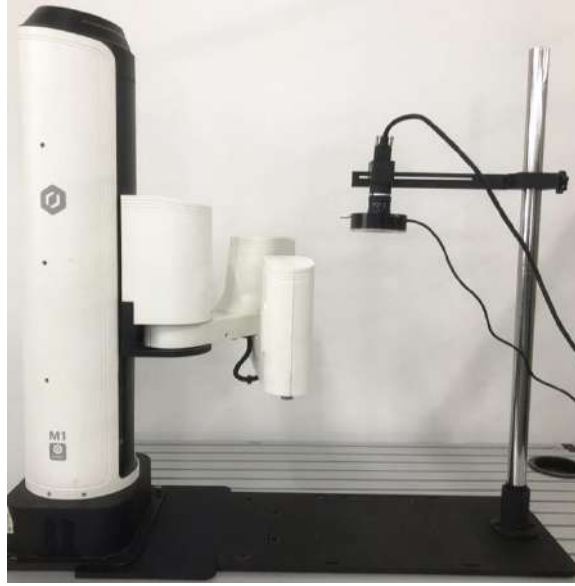

Figure 2.22 Install Dobot M1